

DESIGN SPECIFICATION	
CYLINDER MODEL	PF-1200
CYLINDER SIZE	4.5" DIA
CYLINDER WORKING VOLUME	1275 cc
CYLINDER TOTAL VOLUME	1400 cc
CYLINDER TARE WEIGHT	7.58 lbs
DESIGN PRESSURE	260 psig
TEST PRESSURE	520 psig
DESIGN TEMPERATURE	150° F
INTERNAL FINISH	20ra, ELECTROPOLISH
EXTERNAL FINISH	30ra, ELECTROPOLISH
FILLPORT	6LV-12-VCR-3-12TB7(P)
INLET VALVE	GASFLO, VLV-4445
OUTLET VALVE	GASFLO, VLV-4445
THERMOWELL	NO
DIPTUBE	YES/OUTLET
MATERIAL OF CONSTRUCTION	316L SS
D.O.T. SPECIFICATION	4B-260
TOLERANCE (UNLESS OTHERWISE SPECIFIED)	±.060

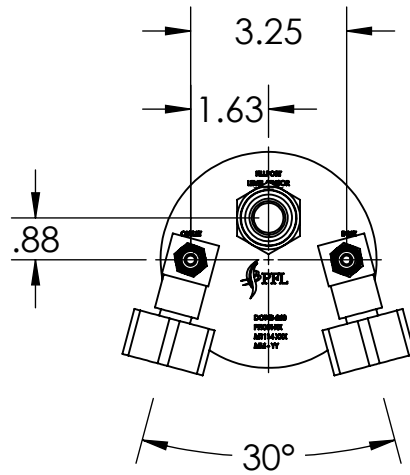

ZONE	REV.	DESCRIPTION	DATE	APPROVED
	1	INITIAL RELEASE	03/06/2014	
	04	UPDATES PER FABRICATION REQUEST	01/13/2015	
	05	REMOVE COUNTERBORE IN HEAD	11/14/2015	
	06	USE ALTERNATIVE BASE	9/21/2017	

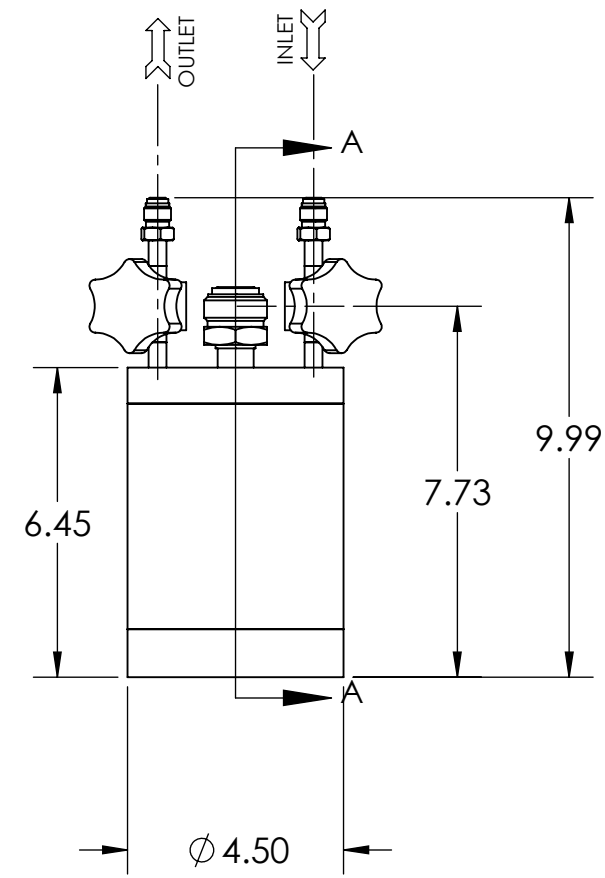
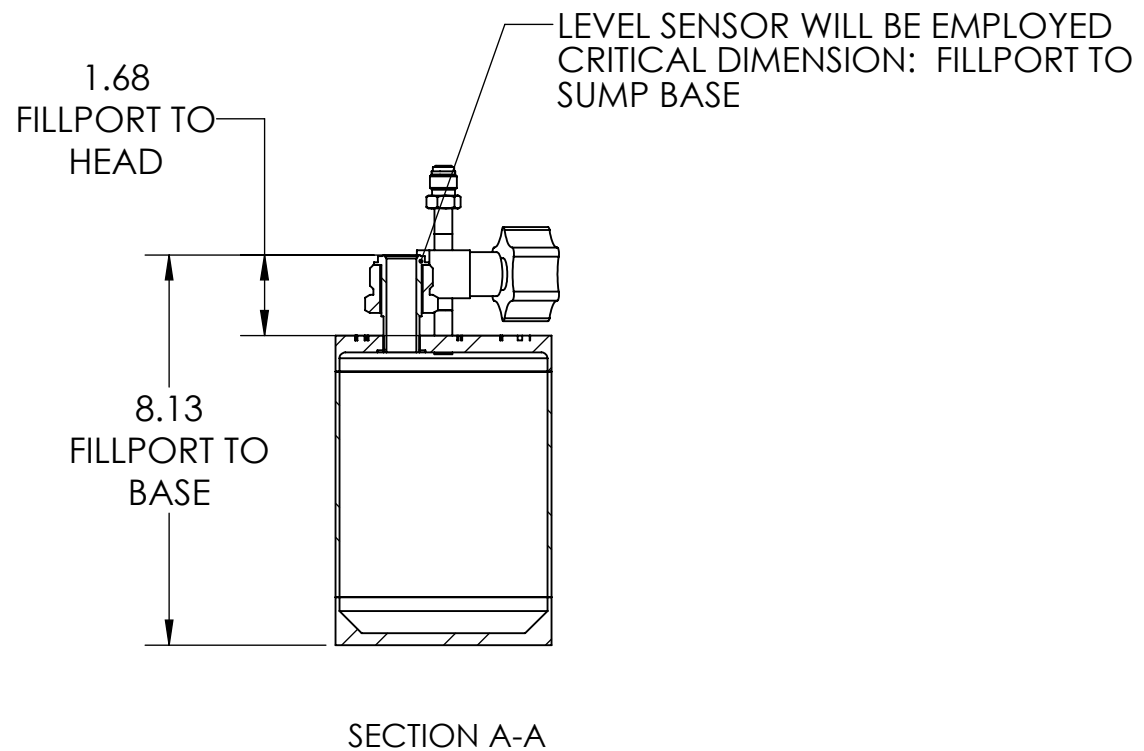
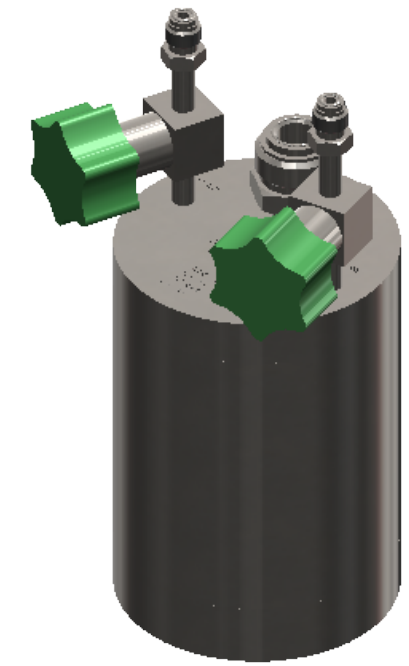

TOLERANCES UNLESS OTHERWISE SPECIFIED		INTERPRET GEOMETRIC TOLERANCING PER THIRD ANGLE PROJECTION		PRECISION FABRICATORS LTD. 171 TOSCA DRIVE STOUGHTON, MA 02072 (781) 341-7242 PHONE (781) 341-7245 FAX																	
ANGULAR:	±0.5° ±0°30'	UNLESS OTHERWISE SPECIFIED: PRIMARY DIMENSIONS ARE INCH. ALTERNATE UNITS ARE MM.																			
ONE PLACE DECIMAL:	±.1in [±.254mm]	<table border="1"> <thead> <tr> <th>NAME</th> <th>DATE</th> <th>TITLE:</th> </tr> </thead> <tbody> <tr> <td>DRAWN</td> <td>JTS 4/26/2013</td> <td>PF1225-G-316L</td> </tr> <tr> <td>CHECKED</td> <td>DBD 7/2/2014</td> <td>SALES</td> </tr> <tr> <td>ENG APPR.</td> <td>DBD 7/6/2014</td> <td></td> </tr> <tr> <td>MFG APPR.</td> <td>DBD 7/31/2014</td> <td></td> </tr> <tr> <td>Q.A.</td> <td>12/31/1799</td> <td></td> </tr> </tbody> </table>		NAME	DATE	TITLE:	DRAWN	JTS 4/26/2013	PF1225-G-316L	CHECKED	DBD 7/2/2014	SALES	ENG APPR.	DBD 7/6/2014		MFG APPR.	DBD 7/31/2014		Q.A.	12/31/1799	
NAME	DATE			TITLE:																	
DRAWN	JTS 4/26/2013			PF1225-G-316L																	
CHECKED	DBD 7/2/2014			SALES																	
ENG APPR.	DBD 7/6/2014																				
MFG APPR.	DBD 7/31/2014																				
Q.A.	12/31/1799																				
TWO PLACE DECIMAL:	±.01in [±.25mm]	SIZE	DWG. NO.	REV																	
THREE PLACE DECIMAL:	±.005in [±.127mm]	B	0177P-0001 Ereztech Sales Only	06																	
BREAK ALL SHARP CORNERS: R.02/0in [R.50/.25mm]		DO NOT SCALE DRAWING																			
SURFACE FINISH: 63 ✓ [1.6] ✓		SCALE: 1:4		SHEET 1 OF 1																	

NOTICE OF CONFIDENTIAL INFORMATION

INFORMATION CONTAINED HEREIN IS CONFIDENTIAL AND IS THE PROPERTY OF PRECISION FABRICATORS LTD. WHERE FURNISHED WITH A PROPOSAL THE RECIPIENT SHALL USE IT SOLELY TO EVALUATE THE PROPOSAL. WHERE FURNISHED TO A CUSTOMER IT SHALL BE USED SOLELY FOR PURPOSES OF INSPECTION INSTALLATION, OR MAINTENANCE. WHERE FURNISHED TO A SUPPLIER IT SHALL BE USED SOLELY IN THE PERFORMANCE OF WORK CONTRACTED FOR BY THIS COMPANY. THE INFORMATION SHALL NOT BE USED OR DISCLOSED BY THE RECIPIENT FOR ANY OTHER PURPOSE WHATSOEVER.