

DESIGN SPECIFICATION	
CYLINDER MODEL	202 SAMPLE THREADED FVCR
CYLINDER SIZE	1" DIA
CYLINDER WORKING VOLUME	50CC
CYLINDER TOTAL VOLUME	50CC
CYLINDER TARE WEIGHT	
DESIGN PRESSURE	300PSI
TEST PRESSURE	600PSI
DESIGN TEMPERATURE	121C
INTERNAL FINISH	10RA, EP
EXTERNAL FINISH	10RA MIRROR
FILLPORT	1/4 FVCR
INLET VALVE	GF VLV-ST-44SS-MFSMFS-PI
OUTLET VALVE	NO
THERMOWELL	NO
DIPTUBE	NO
MATERIAL OF CONSTRUCTION	316L SS
D.O.T. SPECIFICATION	DOT4B-300
TOLERANCE (UNLESS OTHERWISE SPECIFIED)	+/- 0.060

REV.	DESCRIPTION	DATE	APPROVED
2	EREZTECH 50CC SAMPLE, THREADED VLV, FVCR	9/24/2019	
3	ADD VCR LOCK; CAP	9/25/2019	

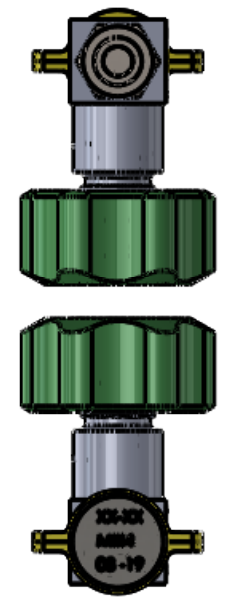

PART NUMBER: 202.3FVR

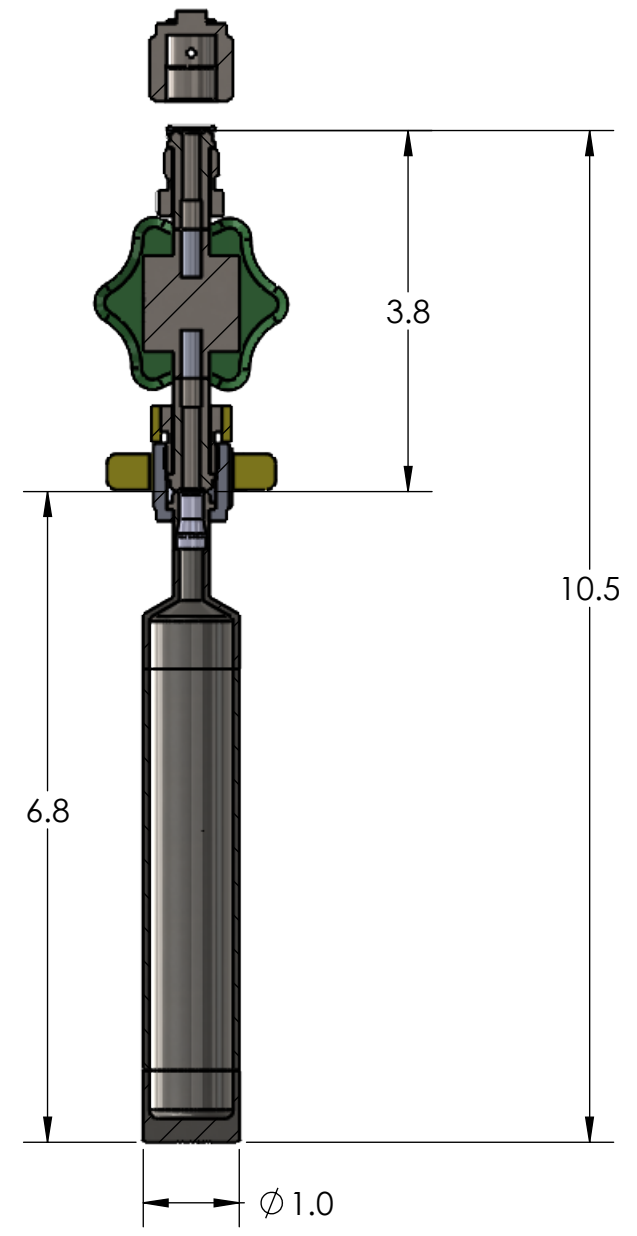
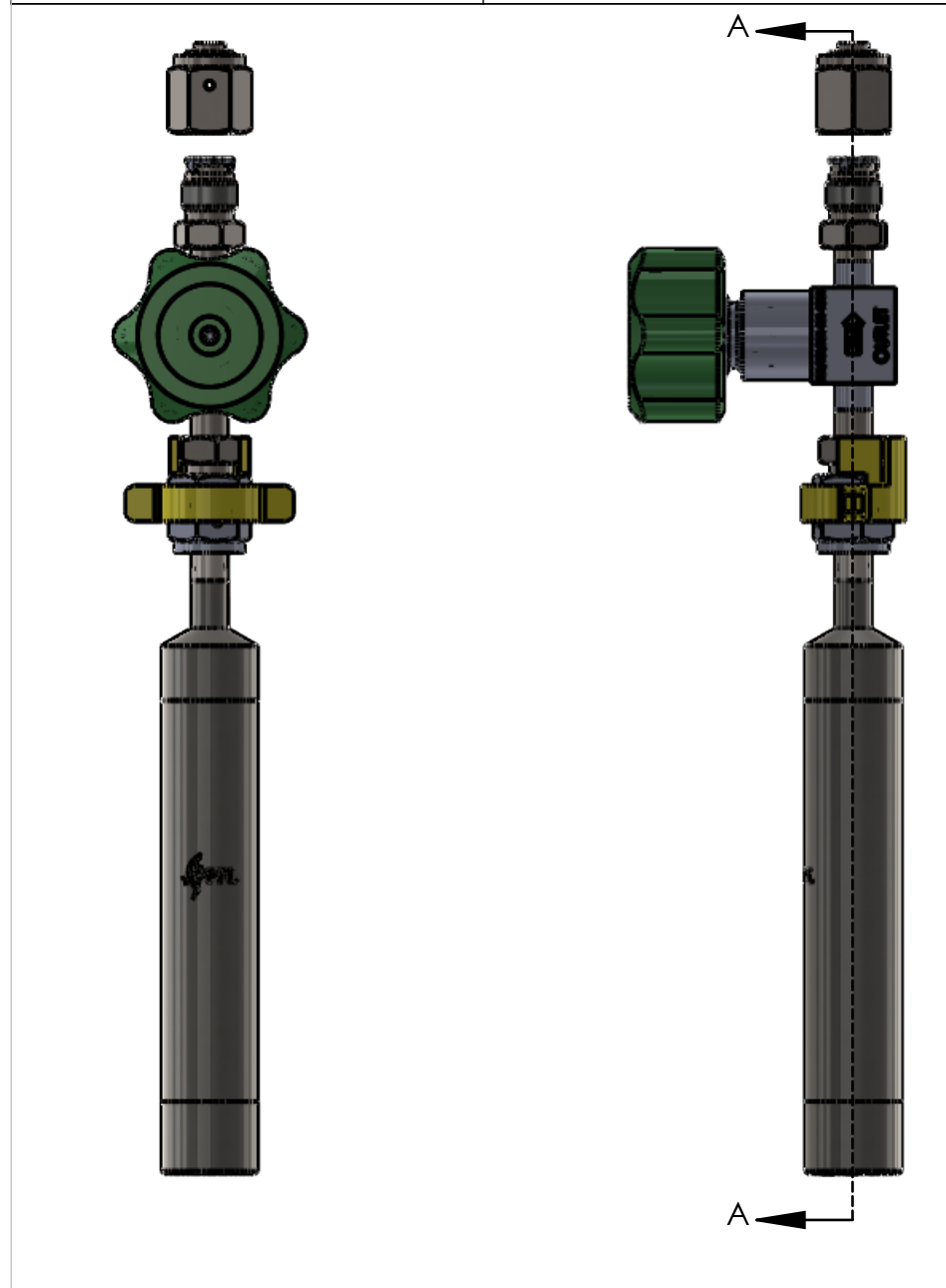
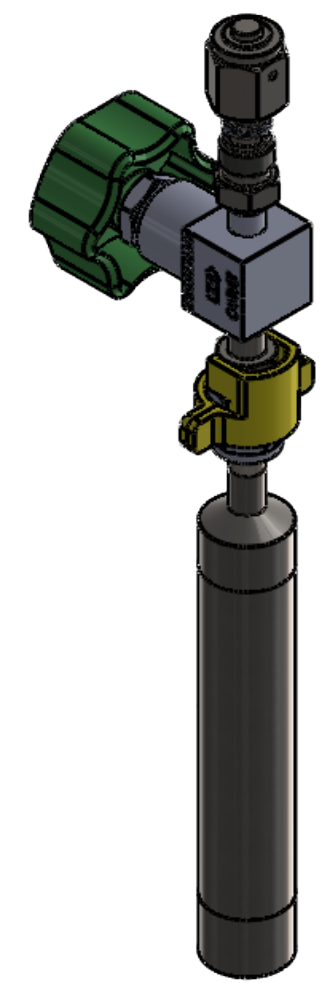

<b>TOLERANCES UNLESS OTHERWISE SPECIFIED</b> ANGULAR: ±0.5° ±0°30' ONE PLACE DECIMAL: ±.1in [±.254mm] TWO PLACE DECIMAL: ±.01in [.25mm] THREE PLACE DECIMAL: ±.005in [±.127mm] BREAK ALL SHARP CORNERS: R.02/0in [R.50/.25mm] SURFACE FINISH: 63 ✓ [1.6] ✓		<b>INTERPRET GEOMETRIC TOLERANCING PER THIRD ANGLE PROJECTION</b> UNLESS OTHERWISE SPECIFIED: PRIMARY DIMENSIONS ARE INCH. ALTERNATE UNITS ARE MM.		<b>PRECISION FABRICATORS LTD.</b> 171 TOSCA DRIVE STOUGHTON, MA 02072 (781) 341-7242 PHONE (781) 341-7245 FAX	
<b>NOTICE OF CONFIDENTIAL INFORMATION</b> INFORMATION CONTAINED HEREIN IS CONFIDENTIAL AND IS THE PROPERTY OF PRECISION FABRICATORS LTD. WHERE FURNISHED WITH A PROPOSAL THE RECIPIENT SHALL USE IT SOLELY TO EVALUATE THE PROPOSAL. WHERE FURNISHED TO A CUSTOMER IT SHALL BE USED SOLELY FOR PURPOSES OF INSPECTION INSTALLATION, OR MAINTENANCE. WHERE FURNISHED TO A SUPPLIER IT SHALL BE USED SOLELY IN THE PERFORMANCE OF WORK CONTRACTED FOR BY THIS COMPANY. THE INFORMATION SHALL NOT BE USED OR DISCLOSED BY THE RECIPIENT FOR ANY OTHER PURPOSE WHATSOEVER.		NAME DATE	TITLE: <b>50CC SAMPLE CYL</b> Sheet1		
DRAWN DBD 6/30/2014 CHECKED DBD ENG APPR. DBD MFG APPR. EJY Q.A. -		SIZE <b>B</b>	DWG. NO. 0202 - SAMPLE CYL, EREZTECH THREADED F- VLV	REV <b>3</b>	SHEET 1 OF 1
DO NOT SCALE DRAWING		SCALE: 1:4			

FOR INTERNAL USE ONLY