

DESIGN SPECIFICATION	
CYLINDER MODEL	0253 - Horiz Vlv 100cc
CYLINDER SIZE	2" DIAMETER
CYLINDER WORKING VOLUME	100cc
TOTAL CYLINDER VOLUME	120cc
CYLINDER TARE WEIGHT	3.77lbs
DESIGN PRESSURE	260 psi
DESIGN TEMPERATURE	250F/121C
INTERNAL FINISH	10ra, MIRROR, ELECTROPOLISH
EXTERNAL FINISH	10ra, MIRROR, ELECTROPOLISH
FILLPORT	SWAGELOK, 1/2 VCR
INLET VALVE	SWAGELOK, SS-DSTW-4
OUTLET VALVE	SWAGELOK, SS-DSTW-4
THERMOWELL	NO
DIPTUBE	YES, INLET
MATERIAL OF CONSTRUCTION	316L SS
TEST PRESSURE	520 psi
D.O.T. SPECIFICATION	4B-260
TOLERANCE (UNLESS OTHERWISE SPECIFIED)	±.060

ZONE	REV.	DESCRIPTION	DATE	APPROVED
	01	INITIAL RELEASE	10/15/2014	
	02	UPDATE DRAWING FORMAT	6/12/2015	

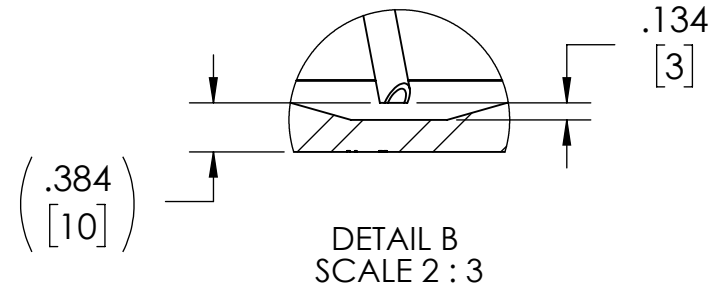
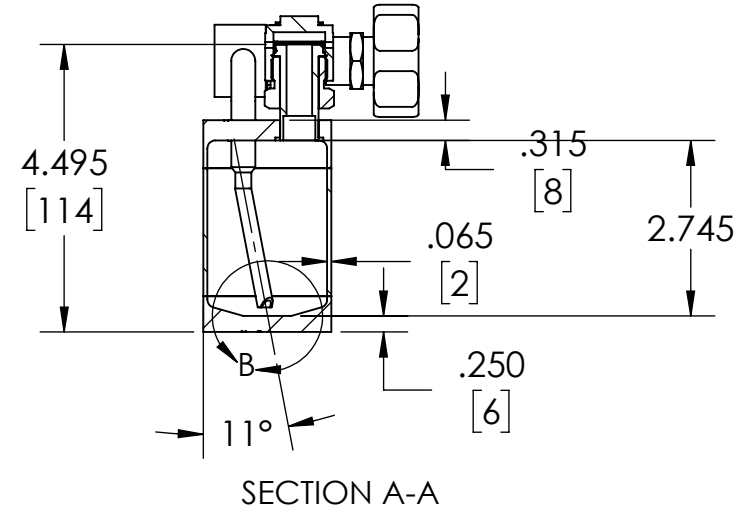
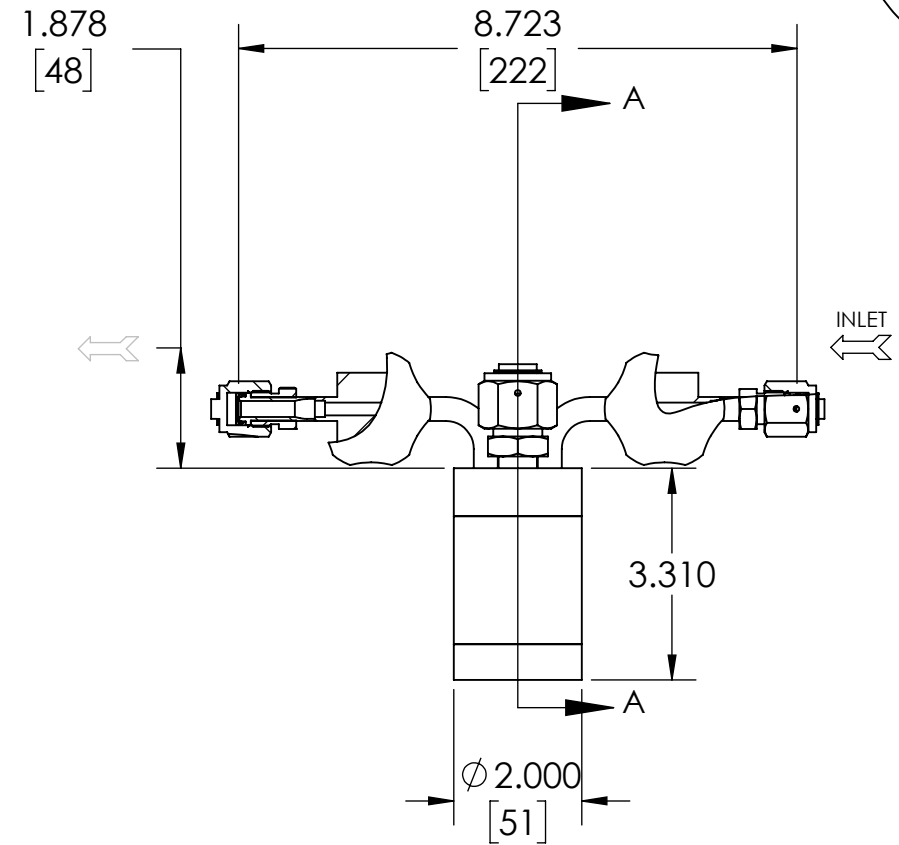
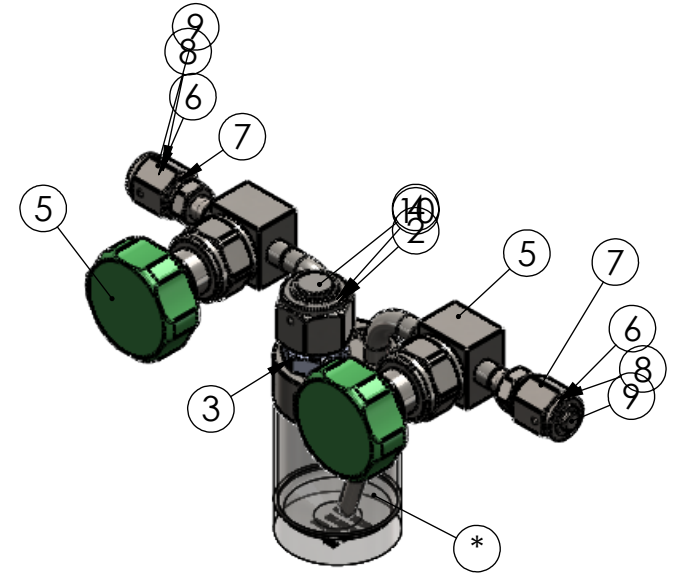
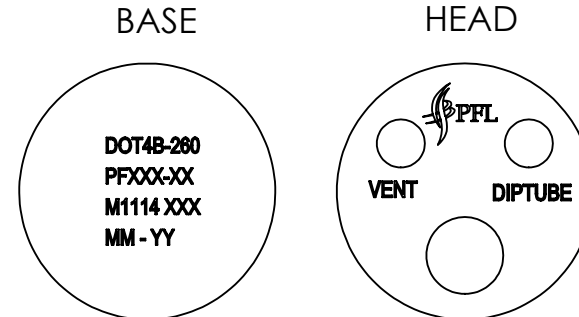
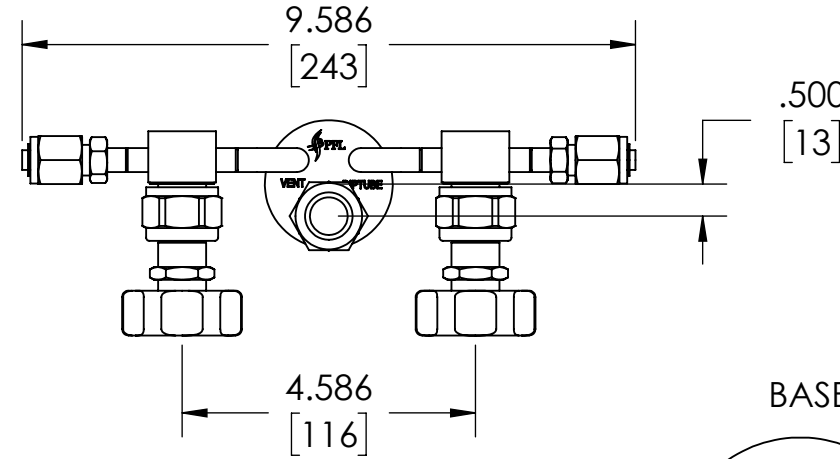

ITEM NO.	PART NUMBER	DESCRIPTION	VENDOR	Default t/QTY.
1	0193-0001	CYLINDER, STAINLESS STEEL, 150ml	PFL	1
2	SS-8-VCR-3	GLAND, 1/2" VCR	SWAGELOK	1
3	SS-8-VCR-4	NUT, MALE, 1/2 VCR	SWAGELOK	1
4	SS-8-VCR-CP	CAP, 1/2 VCR	SWAGELOK	1
5	SS-DSTW4	VALVE, HIGH PURITY 3/8" TBW	SWAGELOK	2
6	6LV-4-HVCR-3-1.19SR	GLAND, HVCR, 3/8" BW, 1.19" LG, UHP	SWAGELOK	2
7	SS-4-VCR-4	NUT, MALE, 1/4 VCR	SWAGELOK	2
8	SS-4-VCR-2-GR	GASKET RETAINER, 1/4"	SWAGELOK	2
9	SS-4-VCR-CP	Swagelok CAP, 1/4" VCR	SWAGELOK	2
10	SS-8-VCR-2-GR	GASKET RETAINER, 1/2"	SWAGELOK	1

TOLERANCES UNLESS OTHERWISE SPECIFIED

ANGULAR: ±0.5° ±0°30'

ONE PLACE DECIMAL: ±.1in [±.254mm]

TWO PLACE DECIMAL: ±.01in [±.25mm]

THREE PLACE DECIMAL: ±.005in [±.127mm]

BREAK ALL SHARP CORNERS: R.02/0.1in [R.50/.25mm]

SURFACE FINISH: 63 ✓ [1.6] ✓

INTERPRET GEOMETRIC TOLERANCING PER THIRD ANGLE PROJECTION

UNLESS OTHERWISE SPECIFIED: PRIMARY DIMENSIONS ARE INCH. ALTERNATE UNITS ARE MM.

PRECISION FABRICATORS LTD.
171 TOSCA DRIVE
STOUGHTON, MA 02072
(781) 341-7241 PHONE
(781) 341-7245 FAX

NAME: MJC DATE: 10/14/2014 TITLE: 0253 - Horiz Vlv

CHECKED: DBD 12/31/1799 CUSTOMER DWG

ENG APPR: DBD 12/31/1799

MFG APPR: EJY 12/31/1799

Q.A. 12/31/1799

DO NOT SCALE DRAWING SCALE: 1:3 SHEET 1 OF 11

INFORMATION CONTAINED HEREIN IS CONFIDENTIAL AND IS THE PROPERTY OF PRECISION FABRICATORS LTD. WHERE FURNISHED TO A CUSTOMER IT SHALL BE USED SOLELY FOR PURPOSES OF INSPECTION, INSTALLATION, OR MAINTENANCE. WHERE FURNISHED TO A SUPPLIER IT SHALL BE USED SOLELY IN THE PERFORMANCE OF WORK CONTRACTED FOR BY THIS COMPANY. THE INFORMATION SHALL NOT BE USED OR DISCLOSED BY THE RECIPIENT FOR ANY OTHER PURPOSE WHATSOEVER.

SIZE: B DWG. NO. 0253-0001 PFL 100cc REV 02
HORIZ. CUST DWG. REV 2