

DESIGN SPECIFICATION	
CYLINDER MODEL	SPS-500
CYLINDER SIZE	
CYLINDER WORKING VOLUME	500cc
TOTAL CYLINDER VOLUME	510cc
CYLINDER TARE WEIGHT	TBD
DESIGN PRESSURE	260 PSI
DESIGN TEMPERATURE	250F HANDLES REMOVED
INTERNAL FINISH	20ra MAX ELECTROPOLISH
EXTERNAL FINISH	20ra MAX
FILLPORT	YES
INLET VALVE	VLV-ST-44SS-TS-M-PI
OUTLET VALVE	VLV-ST-44SS-TS-M-PI
THERMOWELL	NO
DIPTUBE	YES - GAS CHAMBER
MATERIAL OF CONSTRUCTION	316L SS
TEST PRESSURE	520 PSI
D.O.T. SPECIFICATION	4B-260
TOLERANCE (UNLESS OTHERWISE SPECIFIED)	±.030
500CC MEGASOLID	

REVISIONS				
ZONE	REV.	DESCRIPTION	DATE	APPROVED
	1	INITIAL RELEASE - IMPROVED SPS	6/25/2019	

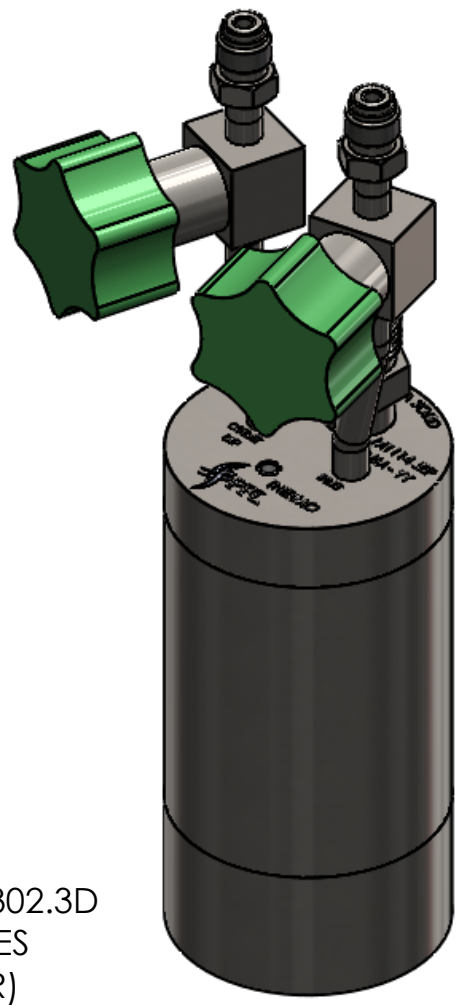
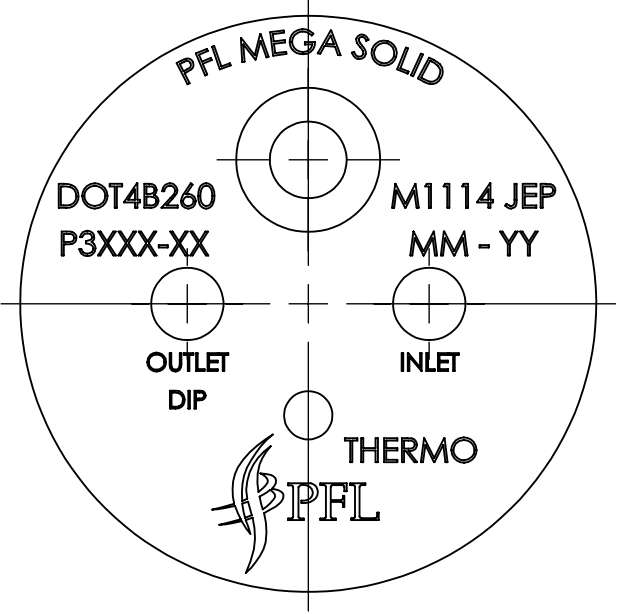
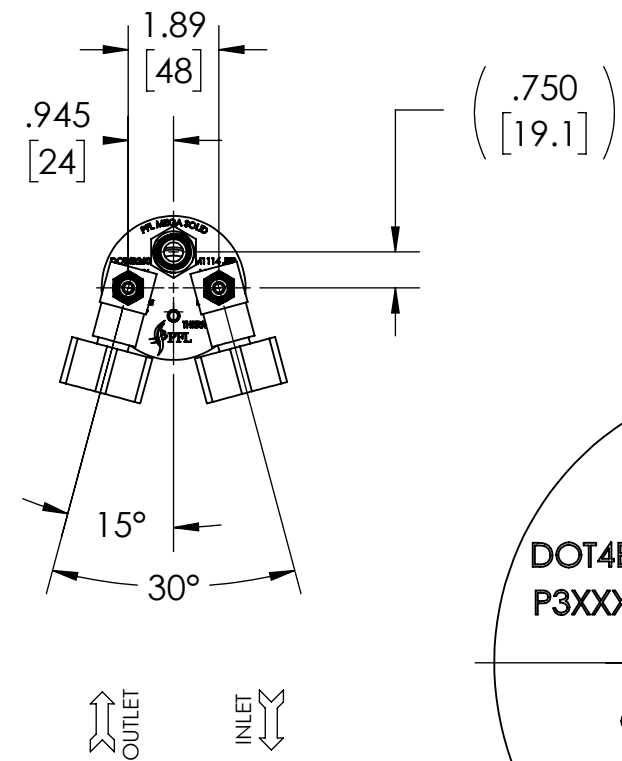

MODEL 302.3D  
(INCLUDES DIVERTER)

SCALE 1 : 2



CP2SCANDIUM, TMI, Others

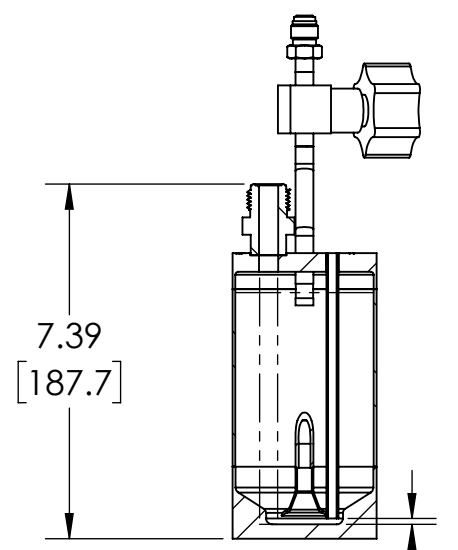

SECTION A-A

.12  
[3]  
THERMO  
GAP

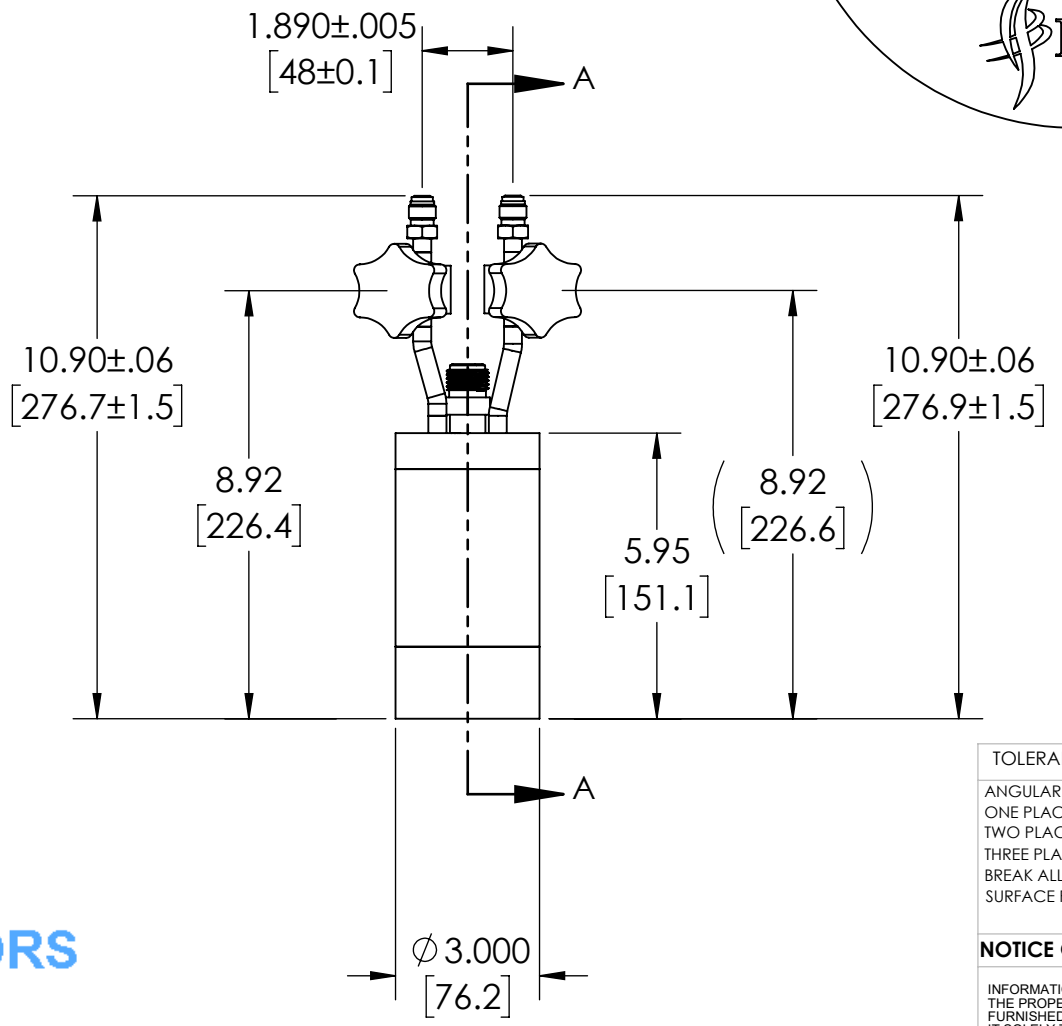

TOLERANCES UNLESS OTHERWISE SPECIFIED

ANGULAR:	±0.5°	±0°30'
ONE PLACE DECIMAL:	±.1in	[±.254mm]
TWO PLACE DECIMAL:	±.01in	[.25mm]
THREE PLACE DECIMAL:	±.005in	[±.127mm]
BREAK ALL SHARP CORNERS:	R.02/01in	[R.50/.25mm]
SURFACE FINISH:	63	[1.6]

INTERPRET GEOMETRIC TOLERANCING PER THIRD ANGLE PROJECTION  
UNLESS OTHERWISE SPECIFIED: PRIMARY DIMENSIONS ARE INCH. ALTERNATE UNITS ARE MM.

**PRECISION FABRICATORS LTD.**  
171 TOSCA DRIVE  
STOUGHTON, MA 02072  
(781) 341-7241 PHONE  
(781) 341-7245 FAX

**NOTICE OF CONFIDENTIAL INFORMATION**

INFORMATION CONTAINED HEREIN IS CONFIDENTIAL AND IS THE PROPERTY OF PRECISION FABRICATORS LTD. WHERE FURNISHED WITH A PROPOSAL THE RECIPIENT SHALL USE IT SOLELY TO EVALUATE THE PROPOSAL. WHERE FURNISHED TO A CUSTOMER IT SHALL BE USED SOLELY FOR PURPOSES OF INSPECTION INSTALLATION, OR MAINTENANCE. WHERE FURNISHED TO A SUPPLIER IT SHALL BE USED SOLELY IN THE PERFORMANCE OF WORK CONTRACTED FOR BY THIS COMPANY. THE INFORMATION SHALL NOT BE USED OR DISCLOSED BY THE RECIPIENT FOR ANY OTHER PURPOSE WHATSOEVER.

NAME	DATE
DRAWN: JTS	5/2/2013
CHECKED:	
ENG APPR.:	
MFG APPR.:	
Q.A.:	

TITLE:	
500CC MEGASOLID	
SIZE: B	DWG. NO. 0302 - 3-500CC-VBC
	Ereztech Sales Only
REV: 1	

**PROPERTY OF PRECISION FABRICATORS  
PROPRIETARY AND CONFIDENTIAL  
DO NOT DISSEMINATE OR COPY**