

DESIGN SPECIFICATION	
CYLINDER MODEL	PFL 331.2
CYLINDER SIZE	2" DIAMETER
CYLINDER WORKING VOLUME	200ml
TOTAL CYLINDER VOLUME	230ml
CYLINDER TARE WEIGHT	4.27 lbs
DESIGN PRESSURE	260 psi
DESIGN TEMPERATURE	250F/121C
INTERNAL FINISH	10ra, MIRROR, ELECTROPOLISH
EXTERNAL FINISH	10ra, MIRROR, ELECTROPOLISH
FILLPORT	SWAGELOK, 1/2 VCR
INLET VALVE	SWAGELOK, 6LV-DSBW6
OUTLET VALVE	SWAGELOK, 6LV-DSBW6
THERMOWELL	NO
DIPTUBE	YES
MATERIAL OF CONSTRUCTION	316L SS
TEST PRESSURE	520 psi
D.O.T. SPECIFICATION	4B-260
TOLERANCE (UNLESS OTHERWISE SPECIFIED)	±.060

ZONE	REV.	DESCRIPTION	DATE	APPROVED
	1	INITIAL RELEASE	06/19/2015	
	2	CORRECT HEAD DIMENSIONS	5/30/2018	

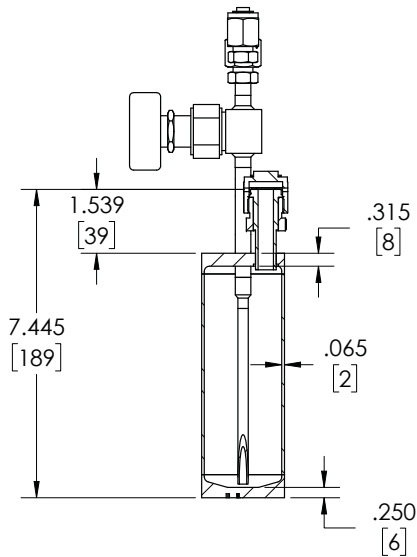

SECTION A-A

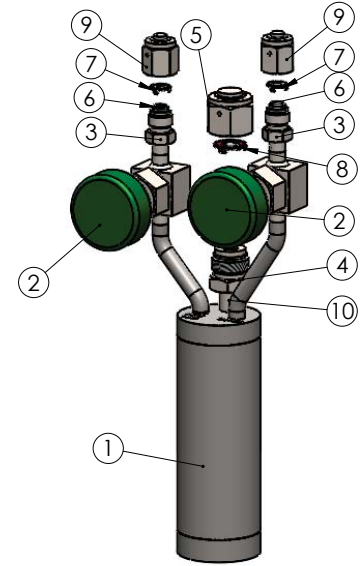
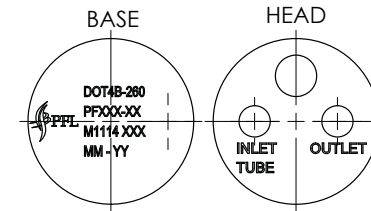
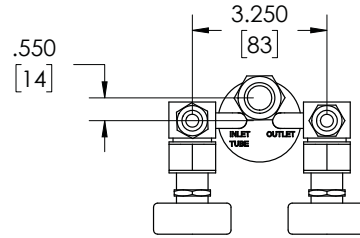
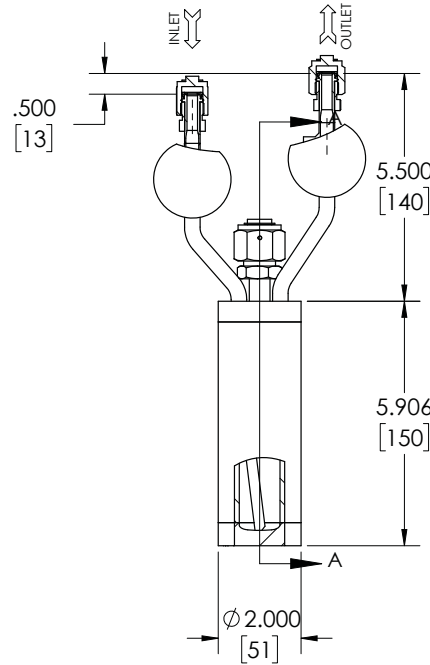

ITEM NO.	PART NUMBER	DESCRIPTION	QTY.
1	0223-0001	CYLINDER, STAINLESS STEEL	1
2	6LV-DSBW6	VALVE, 3/8" BUTT WELD, NUPRO DIAPHRAGM	2
3	SS-4-VCR-4	NUT, MALE, 1/4 VCR	2
4	SS-8-VCR-4	NUT, MALE, 1/2 VCR	1
5	SS-8-VCR-CP	CAP, 1/2 VCR	1
6	6LV-4-HVCR-3-1.19SR	GLAND, HVCR, 3/8" BW, 1.19" LG, UHP	2
7	SS-4-VCR-2-GR	GASKET RETAINER, 1/4"	2
8	SS-8-VCR-2-GR	GASKET RETAINER, 1/2"	1
9	SS-4-VCR-CP	CAP, 1/4" VCR	2
10	SS-8-VCR-3-8TA	GLAND, VCR, 1/2"	1

**TOLERANCES UNLESS OTHERWISE SPECIFIED**

ANGULAR: ±0.5° ±0°30'

ONE PLACE DECIMAL: ±.1in [±2.54mm]

TWO PLACE DECIMAL: ±.01in [±.25mm]

THREE PLACE DECIMAL: ±.005in [±.127mm]

BREAK ALL SHARP CORNERS: R.02/0.1in [R.50/.25mm]

SURFACE FINISH: 63 [1.6]

**INTERPRET GEOMETRIC TOLERANCING PER THIRD ANGLE PROJECTION**

UNLESS OTHERWISE SPECIFIED: PRIMARY DIMENSIONS ARE INCH. ALTERNATE UNITS ARE MM.

**PRECISION FABRICATORS LTD.**  
171 TOSCA DRIVE  
STOUGHTON, MA 02072  
(781) 341-7241 PHONE  
(781) 341-7245 FAX

TITLE: PFL 331.2

**NOTICE OF CONFIDENTIAL INFORMATION**

INFORMATION CONTAINED HEREIN IS CONFIDENTIAL AND IS THE PROPERTY OF PRECISION FABRICATORS LTD. WHERE FURNISHED WITH A PROPOSAL THE RECIPIENT SHALL USE IT SOLELY TO EVALUATE THE PROPOSAL. WHERE FURNISHED TO A CUSTOMER IT SHALL BE USED SOLELY FOR PURPOSES OF INSPECTION, INSTALLATION, OR MAINTENANCE. WHERE FURNISHED TO A SUPPLIER IT SHALL BE USED SOLELY IN THE PERFORMANCE OF WORK CONTRACTED FOR BY THIS COMPANY. THE INFORMATION SHALL NOT BE USED OR DISCLOSED BY THE RECIPIENT FOR ANY OTHER PURPOSE WHATSOEVER.

NAME	DATE
DRAWN: MJC	10/17/2014
CHECKED: DBD	12/29/1799
ENG APPR: DBD	12/29/1799
MFG APPR: RKF	12/29/1799
Q.A.	12/29/1799

SCALE: 1:3

SHEET 1 OF 12