

DESIGN SPECIFICATION

CYLINDER MODEL	100CC SAMPLE CYL, THREADED VLV-F
CYLINDER SIZE	1.5" DIA
CYLINDER WORKING VOLUME	100CC
CYLINDER TOTAL VOLUME	100CC
CYLINDER TARE WEIGHT	
DESIGN PRESSURE	300PSI
TEST PRESSURE	600PSI
DESIGN TEMPERATURE	121C
INTERNAL FINISH	10RA, EP
EXTERNAL FINISH	10RA MIRROR
FILLPORT	1/2" FVCR
INLET VALVE	GF VLV-ST-SS44-MFSMFS-PI
OUTLET VALVE	
THERMOWELL	NO
DIPTUBE	NO
MATERIAL OF CONSTRUCTION	316L SS
D.O.T. SPECIFICATION	DOT4B-300
TOLERANCE (UNLESS OTHERWISE SPECIFIED)	+/-0.060

REV.	DESCRIPTION	DATE	APPROVED
2	ADD VCR LOCK; CORRECT VALVE DESIGNATION	09/25/2019	DBD

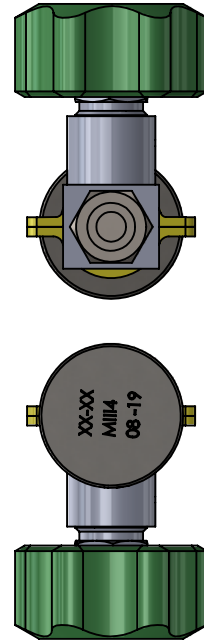

PART NUMBER: 513.2-RVM

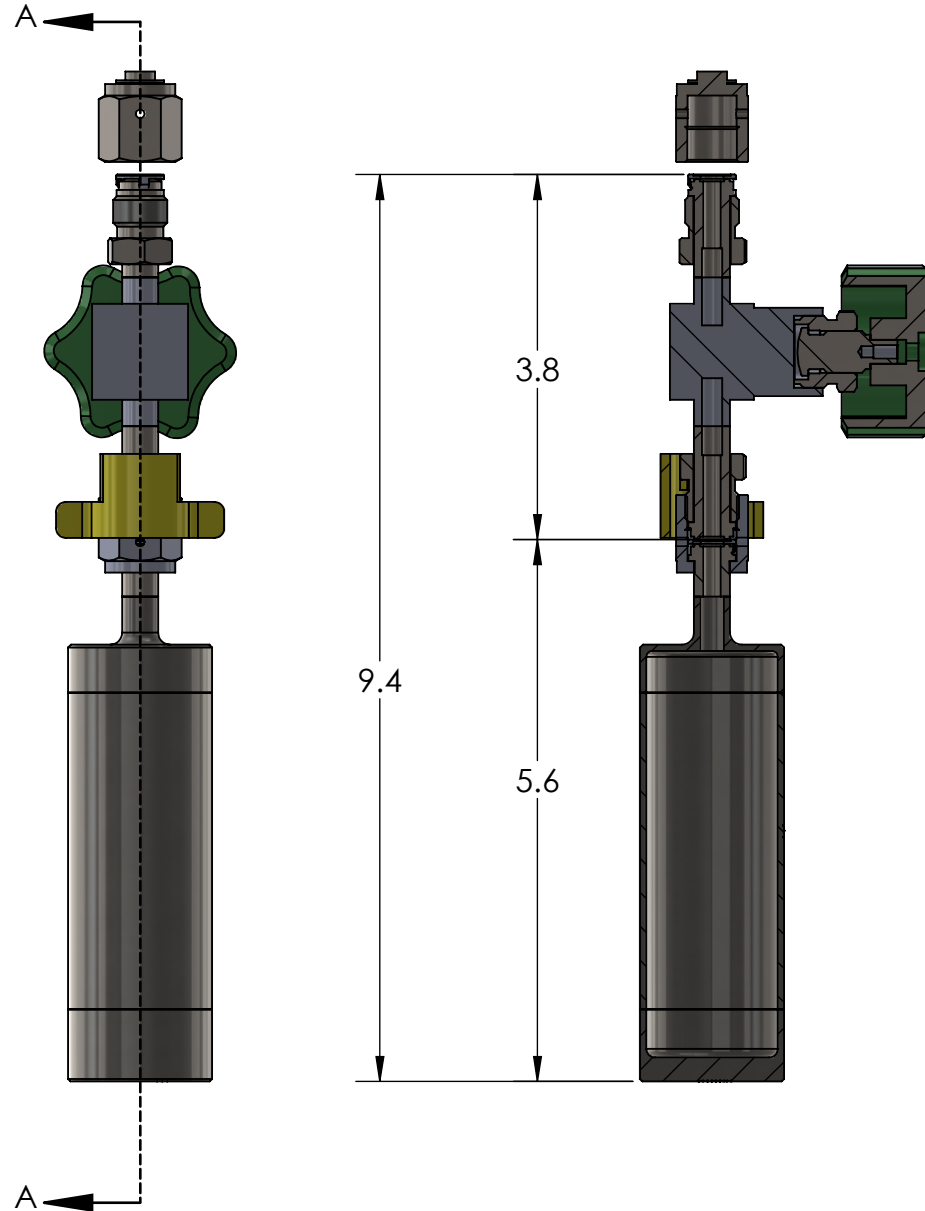
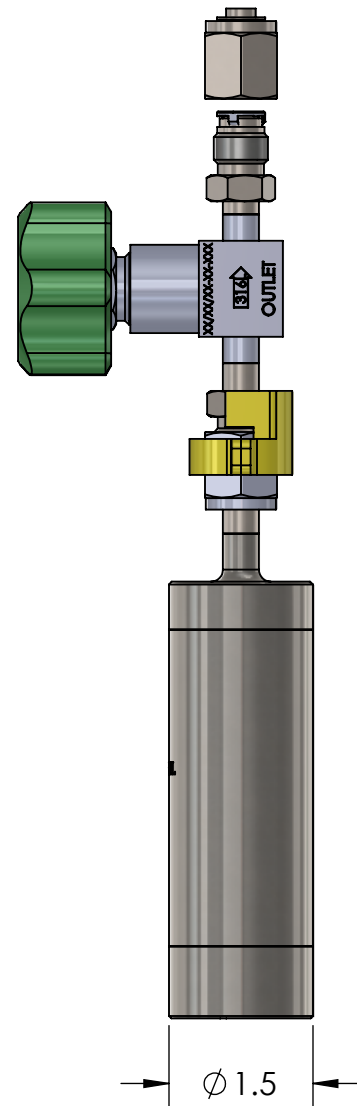
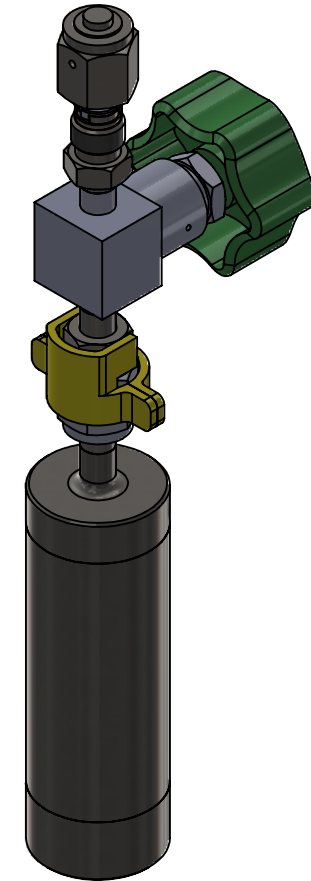

TOLERANCES UNLESS OTHERWISE SPECIFIED
 ANGULAR: ±0.5° ±0°30'
 ONE PLACE DECIMAL: ±.1in [±.254mm]
 TWO PLACE DECIMAL: ±.01in [.25mm]
 THREE PLACE DECIMAL: ±.005in [±.127mm]
 BREAK ALL SHARP CORNERS: R.02/01in [R.50/.25mm]
 SURFACE FINISH: 63 ✓ [1.6] ✓

INTERPRET GEOMETRIC TOLERANCING PER THIRD ANGLE PROJECTION
 UNLESS OTHERWISE SPECIFIED: PRIMARY DIMENSIONS ARE INCH. ALTERNATE UNITS ARE MM.

PRECISION FABRICATORS LTD.
 171 TOSCA DRIVE
 STOUGHTON, MA 02072
 (781) 341-7241 PHONE
 (781) 341-7245 FAX

NOTICE OF CONFIDENTIAL INFORMATION

INFORMATION CONTAINED HEREIN IS CONFIDENTIAL AND IS THE PROPERTY OF PRECISION FABRICATORS LTD. WHERE FURNISHED WITH A PROPOSAL THE RECIPIENT SHALL USE IT SOLELY TO EVALUATE THE PROPOSAL. WHERE FURNISHED TO A CUSTOMER IT SHALL BE USED SOLELY FOR PURPOSES OF INSPECTION INSTALLATION, OR MAINTENANCE. WHERE FURNISHED TO A SUPPLIER IT SHALL BE USED SOLELY IN THE PERFORMANCE OF WORK CONTRACTED FOR BY THIS COMPANY. THE INFORMATION SHALL NOT BE USED OR DISCLOSED BY THE RECIPIENT FOR ANY OTHER PURPOSE WHATSOEVER.

NAME	DATE
DRAWN MJC	10/20/2013
CHECKED	
ENG APPR.	
MFG APPR.	
Q.A.	

TITLE: 100CC SAMPLE CYL	
SIZE B	DWG. NO. 0513 - 100CC SAMPLE CYL - RV-M DWG
SCALE: 1:5	SHEET 2 OF 2

DO NOT SCALE DRAWING