

DESIGN SPECIFICATION	
CYLINDER MODEL	PF-1.2L-AMAT
CYLINDER SIZE	5.516" OD, 5.00" ID
CYLINDER WORKING VOLUME	1200cc
CYLINDER TOTAL VOLUME	1400cc
CYLINDER TARE WEIGHT	19.05 lbs
DESIGN PRESSURE	150 psig
TEST PRESSURE	300 psig
DESIGN TEMPERATURE	-40° TO 180° c
INTERNAL FINISH	10ra, ELECTROPOLISH
EXTERNAL FINISH	15ra, ELECTROPOLISH
FILLPORT	3/4" MVCR
INLET VALVE	AP4540/4657SM (5) AC/695 VS H3
OUTLET VALVE	AP4540/4657SM (5) AC/695 VS H3
THERMOWELL	NO
DIPTUBE	YES/INLET ELBOW
MATERIAL OF CONSTRUCTION	316L SS
D.O.T. SPECIFICATION	DOT4B-150
TOLERANCE (UNLESS OTHERWISE SPECIFIED)	±.010
SEAL TYPE	C-SEAL (TESTED WITH ELASTOMER SEAL)

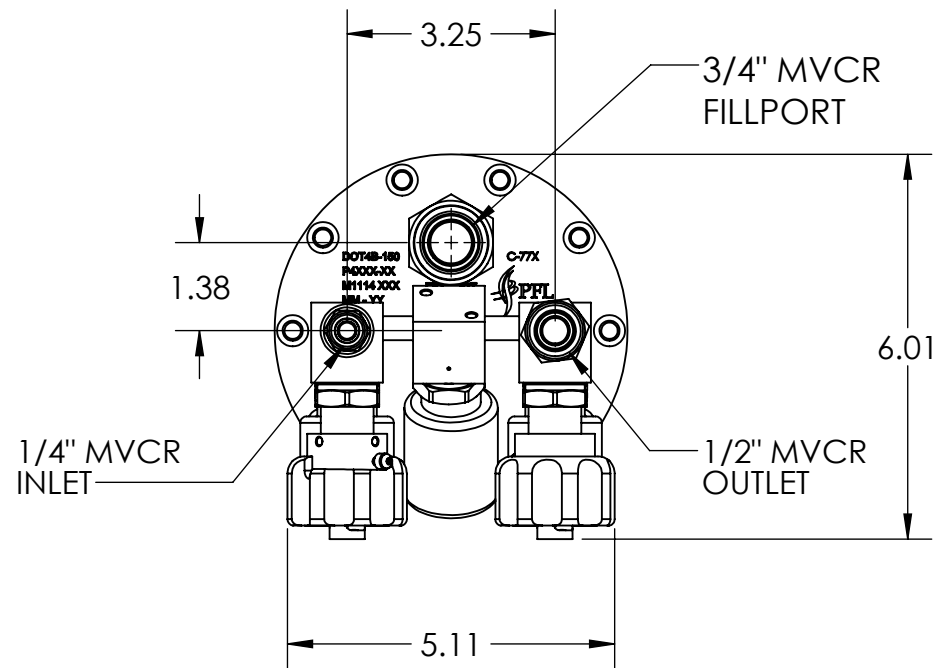

ZONE	REV.	DESCRIPTION	DATE	APPROVED
	01	INITIAL DRAWING	04/28/2017	
	5	STANDARDIZE SEAL GROOVE	11/8/2017	
	6	CORRECT DESIGN TABLE	12/10/2018	

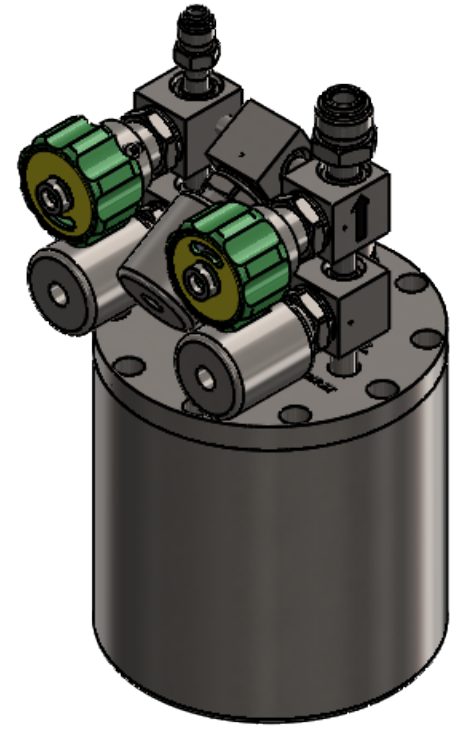

NOTES:

1. HELIUM LEAK TESTED TO 1 X 10⁻⁹ ATM-CC/SEC AS PER SEMI F1 AND ASTM E498
2. CONDUCTANCE @ROOM TEMP Cv>.5 FOR ALL EXCEPT BYPASS VALVE
3. MANUAL VALVE IS LOTO, LOCKED IN CLOSED POSITION
4. MATERIAL IN THE WETTED PATH: SS 316L

FABRICATOR: NOTE SEAL SIZE AND VERIFY INVENTORY

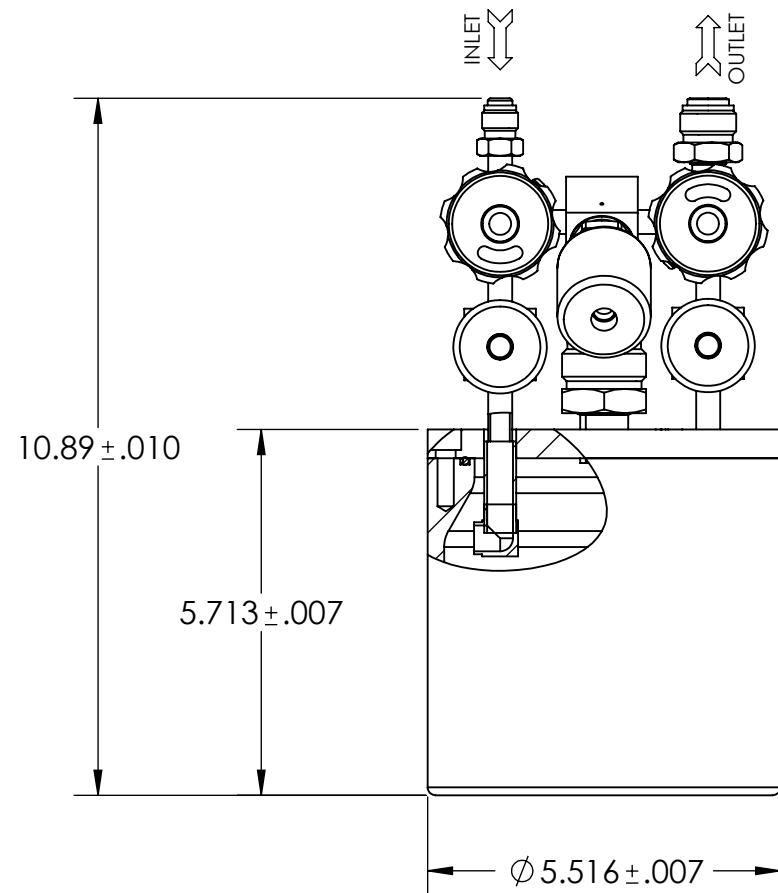
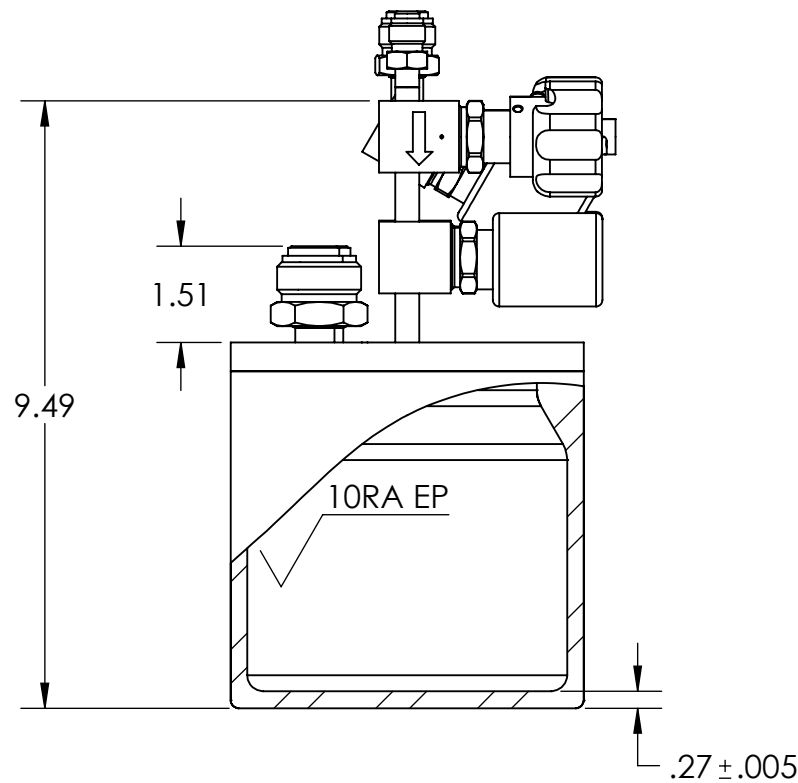

TOLERANCES UNLESS OTHERWISE SPECIFIED		
ANGULAR:	±0.5°	±0°30'
ONE PLACE DECIMAL:	±.1in	[±.254mm]
TWO PLACE DECIMAL:	±.01in	[.25mm]
THREE PLACE DECIMAL:	±.005in	[±.127mm]
BREAK ALL SHARP CORNERS:	R.02/01in	[R.50/.25mm]
SURFACE FINISH:	63	[1.6]

INTERPRET GEOMETRIC TOLERANCING PER THIRD ANGLE PROJECTION
UNLESS OTHERWISE SPECIFIED: PRIMARY DIMENSIONS ARE INCH. ALTERNATE UNITS ARE MM.

PRECISION FABRICATORS LTD.
171 TOSCA DRIVE
STOUGHTON, MA 02072
(781) 341-7242 PHONE
(781) 341-7245 FAX

NOTICE OF CONFIDENTIAL INFORMATION

INFORMATION CONTAINED HEREIN IS CONFIDENTIAL AND IS THE PROPERTY OF PRECISION FABRICATORS LTD. WHERE FURNISHED WITH A PROPOSAL THE RECIPIENT SHALL USE IT SOLELY TO EVALUATE THE PROPOSAL. WHERE FURNISHED TO A CUSTOMER IT SHALL BE USED SOLELY FOR PURPOSES OF INSPECTION INSTALLATION, OR MAINTENANCE. WHERE FURNISHED TO A SUPPLIER IT SHALL BE USED SOLELY IN THE PERFORMANCE OF WORK CONTRACTED FOR BY THIS COMPANY. THE INFORMATION SHALL NOT BE USED OR DISCLOSED BY THE RECIPIENT FOR ANY OTHER PURPOSE WHATSOEVER.

	NAME	DATE	TITLE:
DRAWN	MJC	6/14/2014	PF-1.2L-AMAT
CHECKED			SALES
ENG APPR.			
MFG APPR.			
Q.A.			

SIZE	DWG. NO.	REV
B	0529-2000 Ereztech Sales Only	6

APPROVED: _____ COMPANY: _____
SIGNATURE

NAME: _____ DATE: _____