

DESIGN SPECIFICATION	
CYLINDER MODEL	622 BULK CYLINDER
CYLINDER SIZE	12.75 DIA
CYLINDER WORKING VOLUME	40L
CYLINDER TOTAL VOLUME	42L
CYLINDER TARE WEIGHT	TBD
DESIGN PRESSURE	300psi
TEST PRESSURE	600psi
DESIGN TEMPERATURE	250F/121C
INTERNAL FINISH	10ra MAX ELECTROPOLISH
EXTERNAL FINISH	10ra MAX
FILLPORT	CUST SUPPLIED KITZ VLD4MS-VC 1/4 MVCR
INLET VALVE	CUST SUPPLIED KITZ VLD4MS-VC 1/4 MVCR
OUTLET VALVE	CUST SUPPLIED KITZ VLD4MS-VFC 1/4 MVCR
THERMOWELL	NO
DIPTUBE	YES/OUTLET
MATERIAL OF CONSTRUCTION	316L SS
D.O.T. SPECIFICATION	4B-300
TOLERANCE (UNLESS OTHERWISE SPECIFIED)	±.020

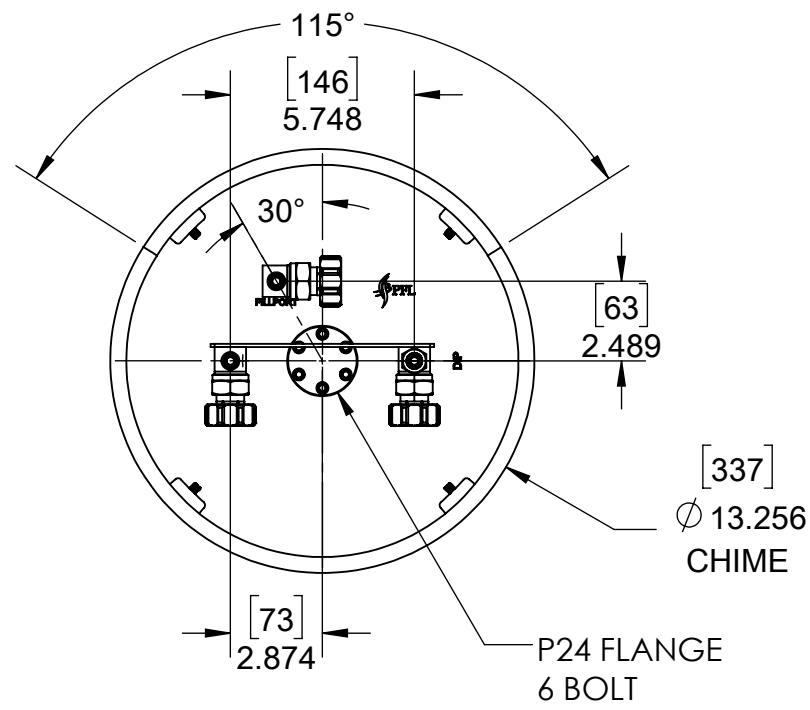

REVISIONS				
ZONE	REV.	DESCRIPTION	DATE	APPROVED
	01	INITIAL RELEASE	8/23/2018	
	10	CORRECT P24 FLANGE; ADD FLANGE DWGS	2/19/2019	
	11	UPDATE P24 FLANGE (ORIG DWG INCORRECT)	3/8/2019	
	12	CORRECT OVERALL HEIGHT; SLOTTED CHIME	4/3/2019	
	B	MODIFY SKIRT DIAMETER	12/5/2019	

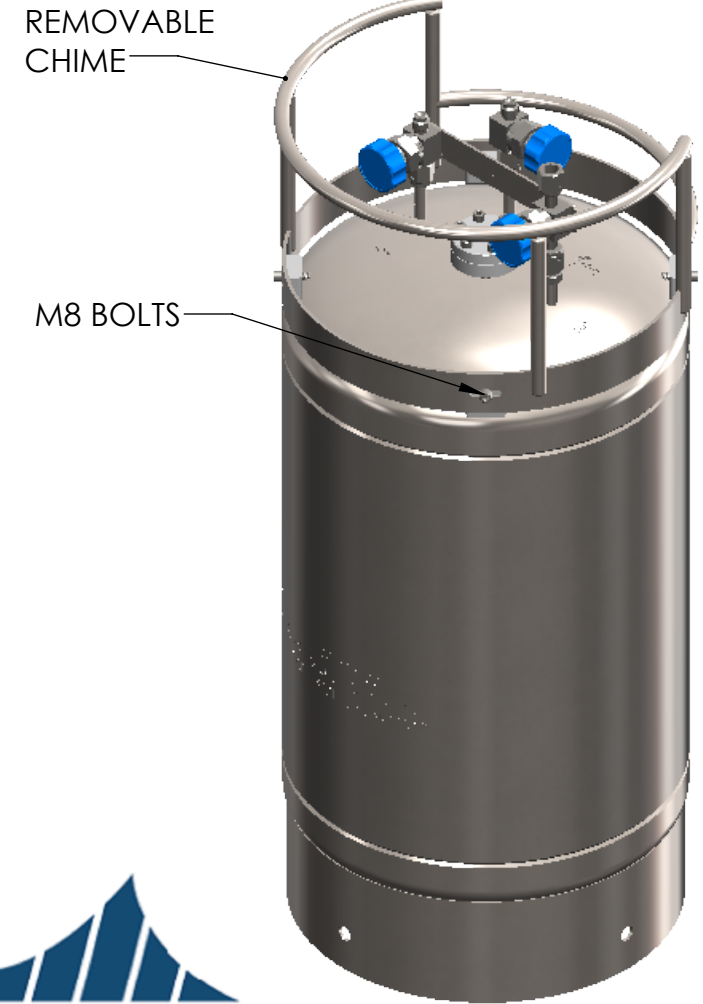
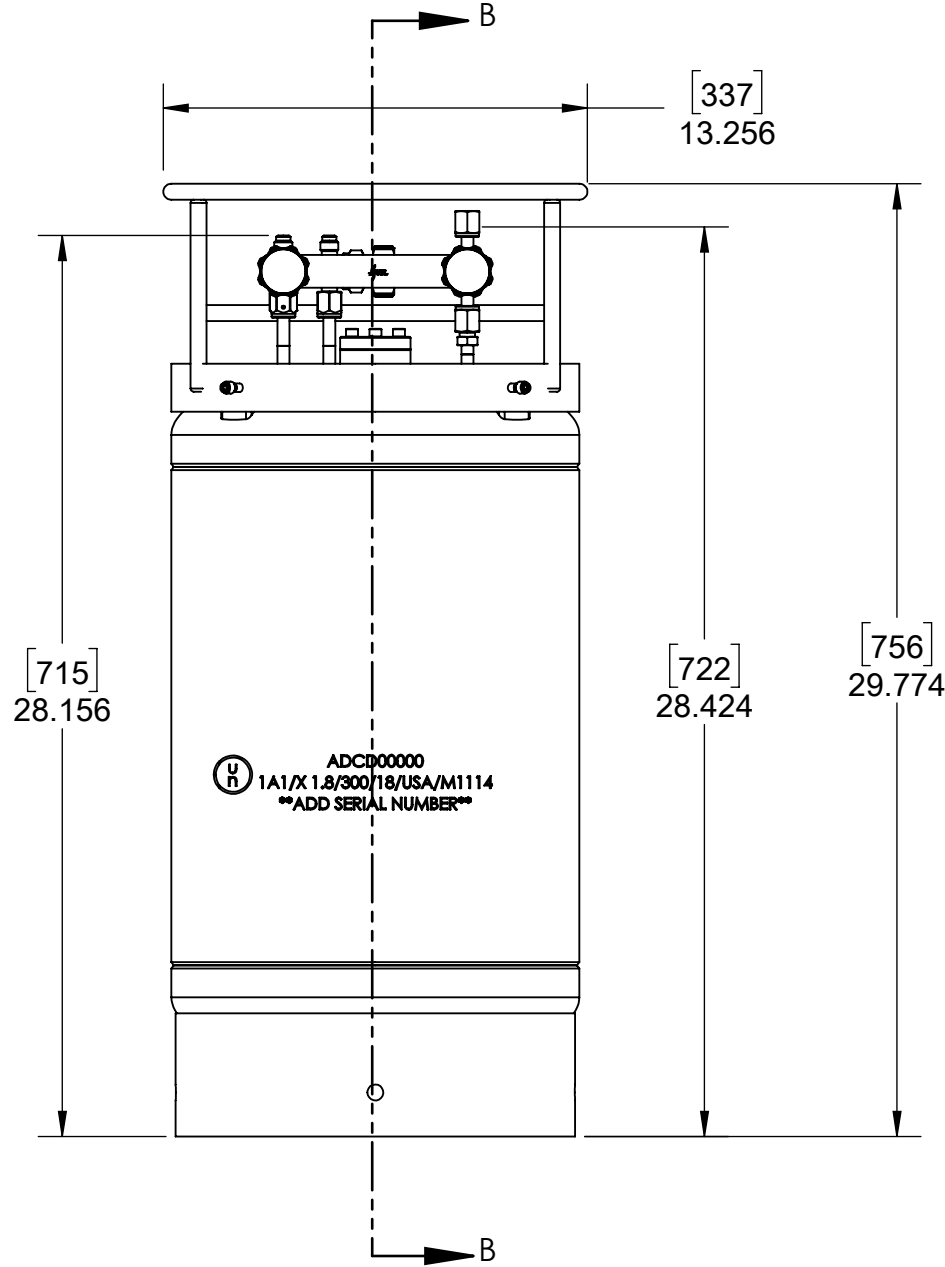
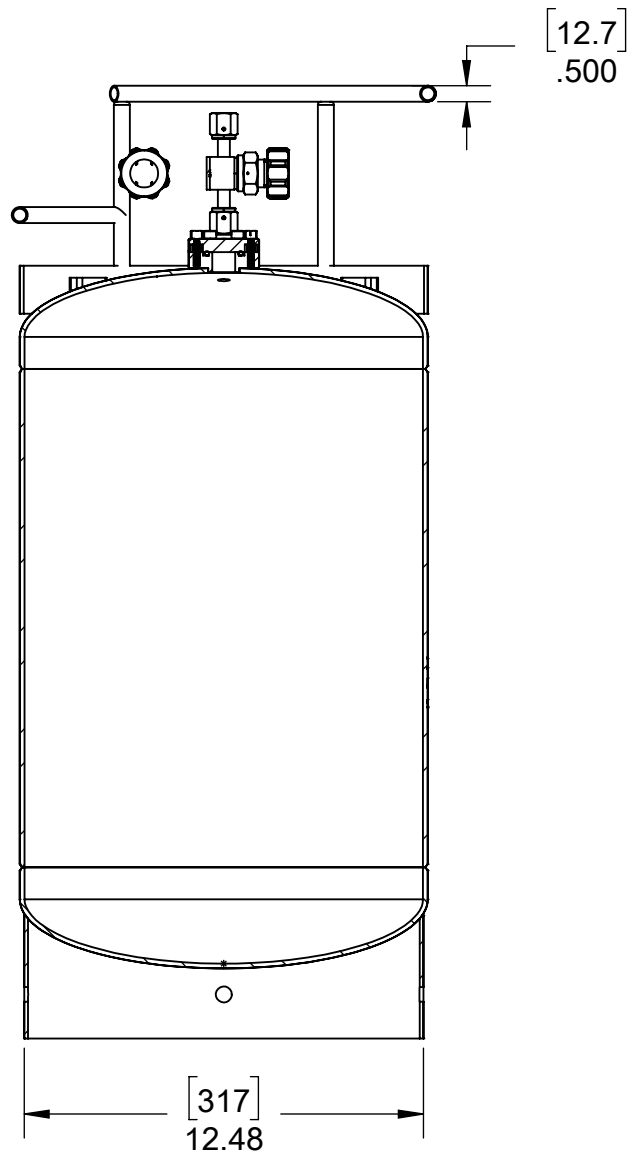

TOLERANCES UNLESS OTHERWISE SPECIFIED
 ANGULAR: ±0.5° ±0°30'
 ONE PLACE DECIMAL: ±.1in [±.254mm]
 TWO PLACE DECIMAL: ±.01in [±.25mm]
 THREE PLACE DECIMAL: ±.005in [±.127mm]
 BREAK ALL SHARP CORNERS: R.02/01in [R.50/.25mm]
 SURFACE FINISH: 63 [1.6]

INTERPRET GEOMETRIC TOLERANCING PER THIRD ANGLE PROJECTION
 UNLESS OTHERWISE SPECIFIED: PRIMARY DIMENSIONS ARE INCH. ALTERNATE UNITS ARE MM.

PRECISION FABRICATORS LTD.
 171 TOSCA DRIVE
 STOUGHTON, MA 02072
 (781) 341-7242 PHONE
 (781) 341-7245 FAX

NOTICE OF CONFIDENTIAL INFORMATION

INFORMATION CONTAINED HEREIN IS CONFIDENTIAL AND IS THE PROPERTY OF PRECISION FABRICATORS LTD. WHERE FURNISHED WITH A PROPOSAL THE RECIPIENT SHALL USE IT SOLELY TO EVALUATE THE PROPOSAL. WHERE FURNISHED TO A CUSTOMER IT SHALL BE USED SOLELY FOR PURPOSES OF INSPECTION INSTALLATION, OR MAINTENANCE. WHERE FURNISHED TO A SUPPLIER IT SHALL BE USED SOLELY IN THE PERFORMANCE OF WORK CONTRACTED FOR BY THIS COMPANY. THE INFORMATION SHALL NOT BE USED OR DISCLOSED BY THE RECIPIENT FOR ANY OTHER PURPOSE WHATSOEVER.

	NAME	DATE
DRAWN	MJC	8/24/2018
CHECKED	DBD	8/24/2018
ENG APPR.	DBD	8/24/2018
MFG APPR.	EJY	8/24/2018
Q.A.		8/24/2018

TITLE:	
ALJ 40L	
CUSTOMER DWG	
SIZE	DWG. NO.
B	0622-0001 - Ereztech Sales Only
REV	B