

DESIGN SPECIFICATION	
CYLINDER MODEL	667 SINGLE PORT, HT
CYLINDER SIZE	2" DIAMETER
CYLINDER WORKING VOLUME	150ml
TOTAL CYLINDER VOLUME	160ml
CYLINDER TARE WEIGHT	1.86 LBS
DESIGN PRESSURE	300PSI
DESIGN TEMPERATURE	600F/300C
INTERNAL FINISH	10ra, MIRROR, ELECTROPOLISH
EXTERNAL FINISH	10ra, MIRROR, ELECTROPOLISH
FILLPORT	1/2" MVCR
INLET VALVE	N/A
OUTLET VALVE	SS-4H-TW 1/4" MVCR
THERMOWELL	NO
DIPTUBE	NO
MATERIAL OF CONSTRUCTION	316L SS
TEST PRESSURE	600PSI
D.O.T. SPECIFICATION	4B-300
TOLERANCE (UNLESS OTHERWISE SPECIFIED)	±.060

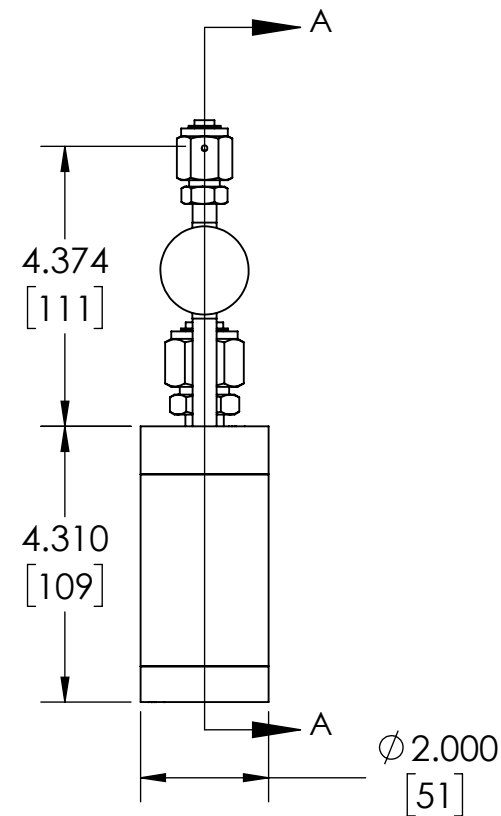
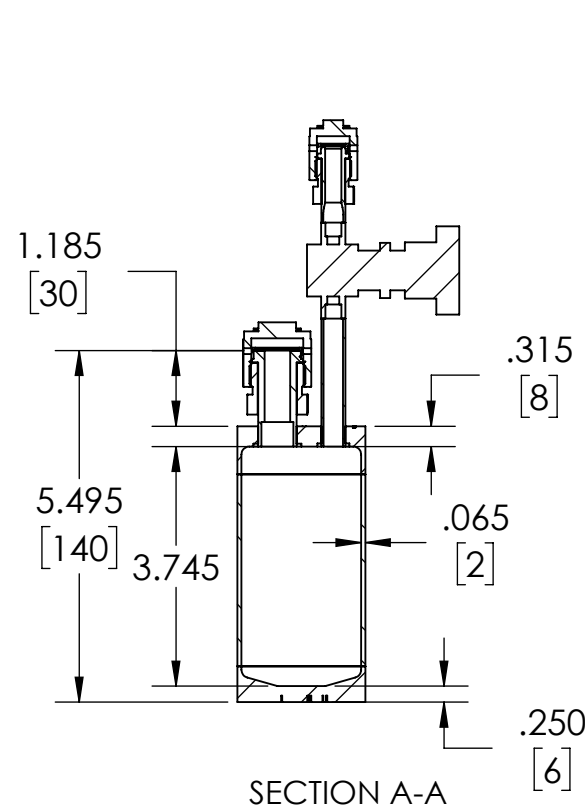
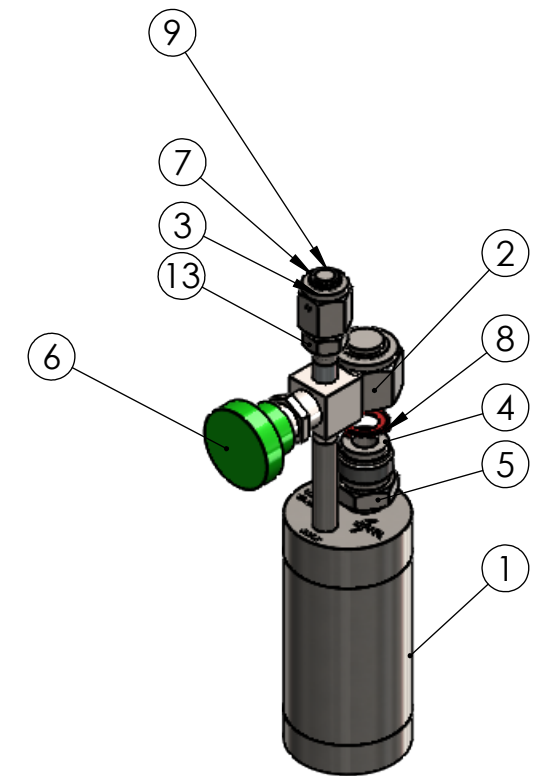
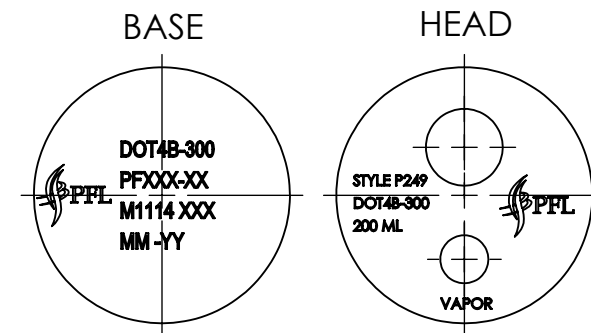
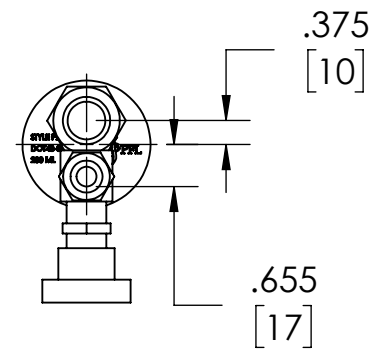

ITEM NO.	VENDOR NUMBER	DESCRIPTION	VENDOR	QTY.
1	0249-0001	CYLINDER, STAINLESS STEEL, 200ml	PFL	1
2	SS-8-VCR-CP	CAP, 1/2 VCR	SWAGELOK	1
3	6LV-4-HVCR-3-1.19SRP	GLAND, HVCR, 3/8" BW, 1.19" LG, UHP	SWAGELOK	1
4	SS-8-VCR-3	GLAND, 1/2" VCR	SWAGELOK	1
5	SS-8-VCR-4	NUT, MALE, 1/2 VCR	SWAGELOK	1
6	SS-4H-TW	VALVE, HIGH TEMPERATURE	SWAGELOK	1
7	SS-4-VCR-2-GR	GASKET RETAINER, 1/4"	SWAGELOK	1
8	SS-8-VCR-2-GR	GASKET RETAINER, 1/2"	SWAGELOK	1
9	SS-4-VCR-CP	CAP, 1/4" VCR	SWAGELOK	1
13	SS-4-VCR-4	NUT, MALE, 1/4 VCR	SWAGELOK	1

TOLERANCES UNLESS OTHERWISE SPECIFIED		INTERPRET GEOMETRIC TOLERANCING PER THIRD ANGLE PROJECTION		PRECISION FABRICATORS LTD. 171 TOSCA DRIVE STOUGHTON, MA 02072 (781) 341-7241 PHONE (781) 341-7245 FAX
ANGULAR:	±0.5° ±0°30'	UNLESS OTHERWISE SPECIFIED: PRIMARY DIMENSIONS ARE INCH. ALTERNATE UNITS ARE MM.		
ONE PLACE DECIMAL:	±.1in [±.254mm]	DRAWN	MJC	10/1/2014
TWO PLACE DECIMAL:	±.01in [±.25mm]	CHECKED	DBD	
THREE PLACE DECIMAL:	±.005in [±.127mm]	ENG APPR.	DBD	
BREAK ALL SHARP CORNERS: R.02/01in [R.50/.25mm]		MFG APPR.	EJY	
SURFACE FINISH: 63 ✓ [1.6] ✓		Q.A.		
NOTICE OF CONFIDENTIAL INFORMATION		TITLE:		667 SINGLE PORT, HT
INFORMATION CONTAINED HEREIN IS CONFIDENTIAL AND IS THE PROPERTY OF PRECISION FABRICATORS LTD. WHERE FURNISHED WITH A PROPOSAL THE RECIPIENT SHALL USE IT SOLELY TO EVALUATE THE PROPOSAL. WHERE FURNISHED TO A CUSTOMER IT SHALL BE USED SOLELY FOR PURPOSES OF INSPECTION INSTALLATION, OR MAINTENANCE. WHERE FURNISHED TO A SUPPLIER IT SHALL BE USED SOLELY IN THE PERFORMANCE OF WORK CONTRACTED FOR BY THIS COMPANY. THE INFORMATION SHALL NOT BE USED OR DISCLOSED BY THE RECIPIENT FOR ANY OTHER PURPOSE WHATSOEVER.		CUSTOMER DWG		
		DO NOT SCALE DRAWING	SCALE: 1:3	SHEET 1 OF 9